

## GR04\_GR05 SERIES LED GROW LIGHT HIGH BAY



### \* Product features:

- High-quality LEDs provided by Everlight/ Nationstar/ Samsung/ Seoul Semiconductor/ Nichia/ Lumiled with excellent performance
- High output PPF: up to 360 ( $\mu\text{mol/s}$ )
- Aluminum fin heatsink design with perfect heat dissipation
- 0-10 V dimming
- IP65, IK08, Class I
- KC certified
- Long life span: up to 30,000 hours, saving the maintenance cost
- Option:
  - GR04: Perfect spectrum including UVA to increase nutrients in fruit, prevent insect, stimulate growth and control flowering; suitable for growing medicinal plants, ginseng, tomatoes, strawberries, grapes, watermelons, cantaloupe, bell peppers, orchids, etc. in greenhouses
  - GR05: Perfect spectrum for growing flowers, fruits, vegetables, algae and orchids in greenhouses





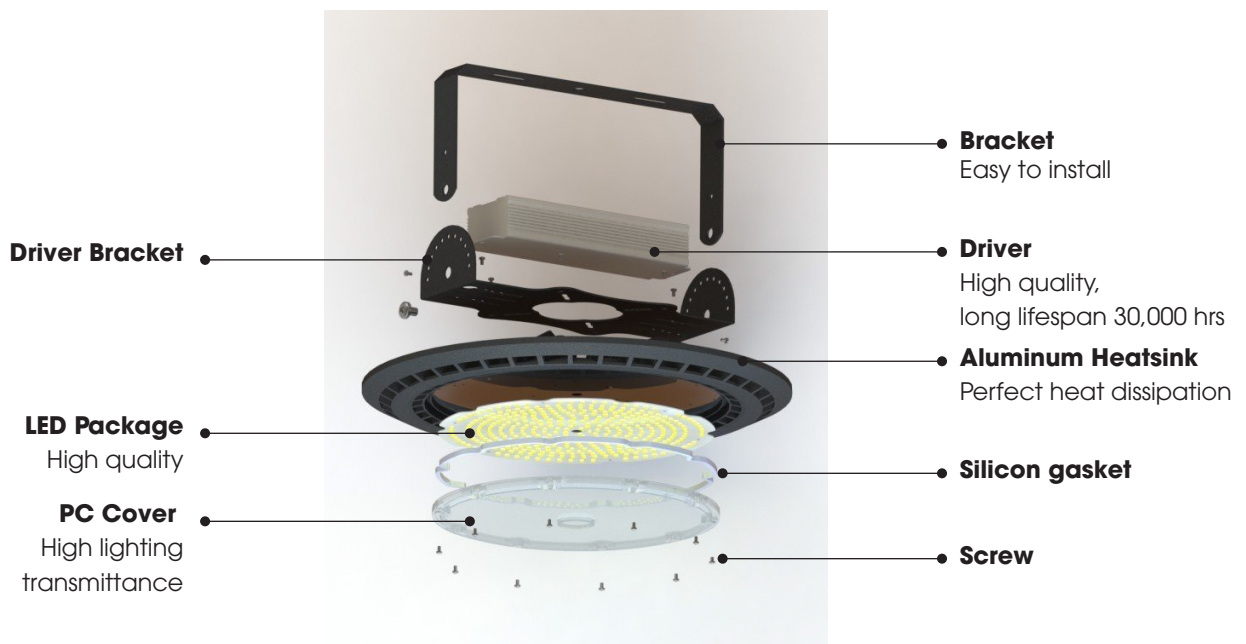

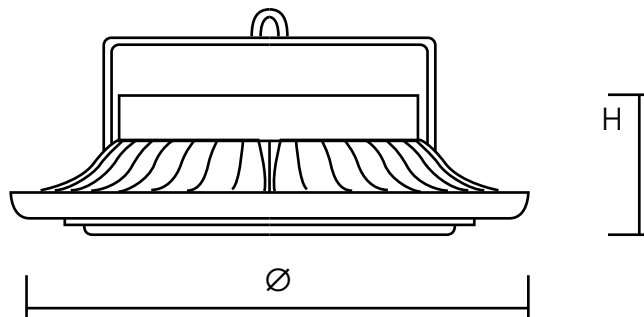

## PRODUCT DETAILS



## PRODUCT SPECIFICATIONS



Model	Dimension ØxH (mm)	Power (W)	Voltage (V)	Frequency (Hz)	Power factor	Photosynthetic Photon Flux (µmol/s)	Photosynthetic Photon Efficacy (µmol/J)	IP	Beam angle (°)	Dimmable	Life span (hrs)	Market
HB.GR04 250/105W	250x150	105	220	60	0.9	190	1.8	65	120	0-10V	30,000	
HB.GR04 310/150W	310x185	150	220	60	0.9	270	1.8	65	120	0-10V	30,000	
HB.GR04 360/200W	360x185	200	220	60	0.9	360	1.8	65	120	0-10V	30,000	
HB.GR05 250/105W	250x150	105	220	60	0.9	145	1.4	65	120	0-10V	30,000	
HB.GR05 310/150W	310x185	150	220	60	0.9	210	1.4	65	120	0-10V	30,000	
HB.GR05 360/200W	360x185	200	220	60	0.9	275	1.4	65	120	0-10V	30,000	

**Capacity: 0.5 million pieces per year**

**Customizable:** Power (105/150/200W), Voltage (120/220÷240/100÷277), PF, Photosynthetic Photon Flux, lifespan, etc.

## SPECTRUM

HB.GR04

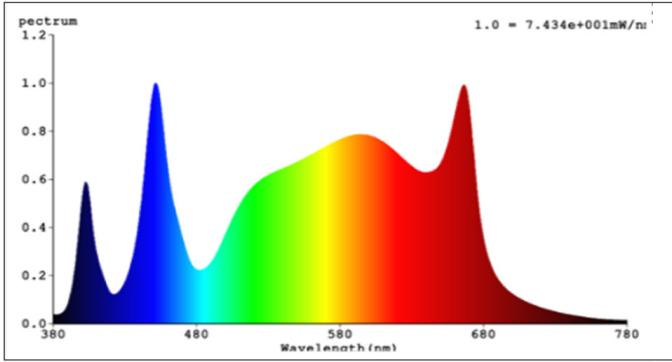

HB.GR05

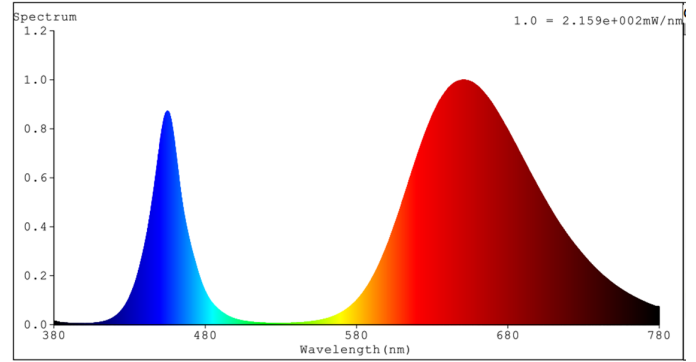

## PACKING AND TRANSPORTATION



Type of lamps	Quantity in master box (pcs)	Estimated quantity / 20'DC (pcs)	Estimated quantity / 40'HC (pcs)
HB 250/105W	1	2 137	4 907
HB 310/150W	1	1 411	3 239
HB 360/200W	1	1 055	2 423



*Customizable according to customer's request*



**Exported market: South Korea, etc**



**RANG DONG LIGHT SOURCE AND VACUUM FLASK JOINT STOCK COMPANY**

Add: 87- 89 Ha Dinh Street, Thanh Xuan, Hanoi, Vietnam  
 Tel: (84-24) 3 858 4310 / 3 858 4165  
 Fax: (84-24) 3 858 5038  
 Email: export@rangdong.com.vn



*Specifications are subject to change without prior notice*